

Jetflow 3™

SACHET 600ml

A single component pneumatic bead and spray applicator for sachets

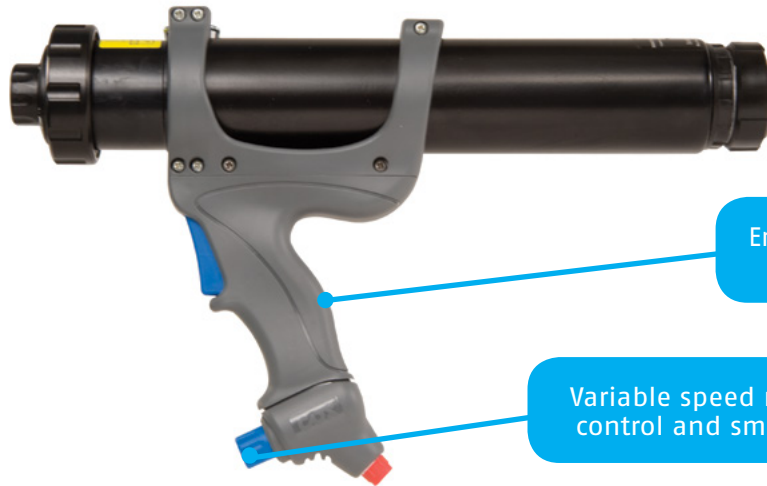

Ergonomically designed handle for comfort.

Variable speed regulator for precise control and smooth material flow.

PRODUCT FEATURES:

- Versatile tool for bead and spray patterns – easy change between bead and spray with just one twist.
- Very light and well-balanced tool to reduce operator fatigue.
- Built-in silencer (less than 70dB) for user-friendly environment.
- Specific nozzle range available.
- 6.8bar (100psi) regulator as standard (others available).

Standard: 6.8 bar (100 psi) ●
Options available: 3.4 bar (50 psi) ●
 5.2 bar (75 psi) ●
 8.5 bar (125 psi) ○

COMPRESSOR GUIDE

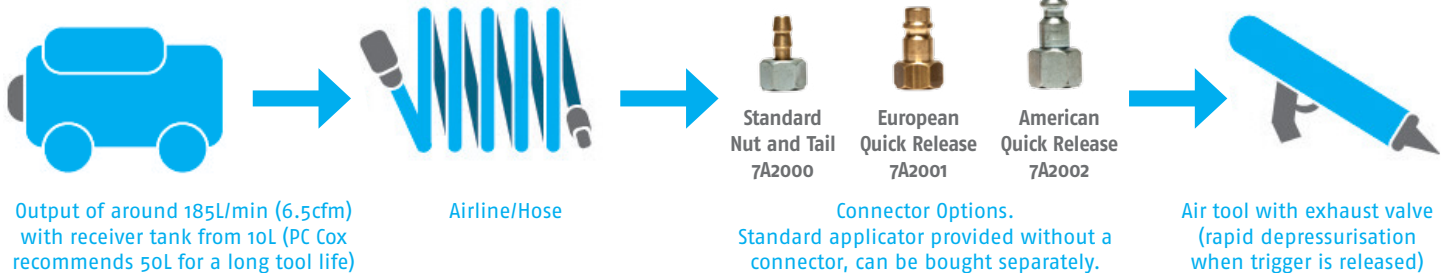

The **Cox Jetflow 3** is part of a range of mid-powered pneumatic applicators. Designed for use with low to medium viscosity sealants and adhesives, the Jetflow 3 is ideal for professional and semi-professional users.

For more information call +44(0)1635 264500
 Or visit www.pccox.co.uk



The original

TECHNICAL DATASHEET

Jetflow 3™ SACHET 600ml



A single component pneumatic bead and spray applicator for sachets

APPLICATIONS:

- For low to medium viscosity
- Sachet volumes: 310ml, 400ml, 600ml

SPECIFICATIONS:

- Max Pneumatic Pressure: 6.8bar (100psi) (others available)
- Barrel Length: 444.8mm
- Maximum Thrust: 1.45kN
- Tool Weight: 1.47 kg
- Tool Material: Glass filled nylon handle, anodised aluminium barrel
- Certificates: ISO, REACH, CE, EN
- Packaging Options: 1 per box

WEB LINKS:

- Academy video
www.pccox.co.uk/en/cox-academy
- Spare parts diagram
www.pccox.co.uk/en/exploded-diagrams

OTHER MODELS AVAILABLE:

- Jetflow 3 Compact Combi
- Jetflow 3 Cartridge

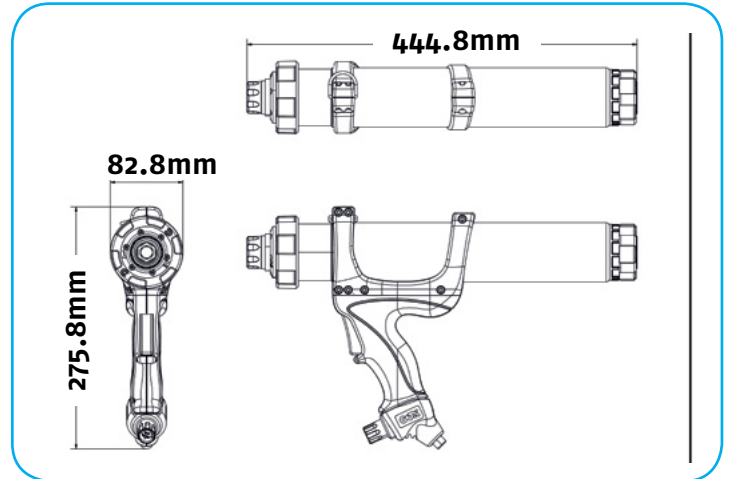

SACHETS:

310ml:



400ml:



600ml:

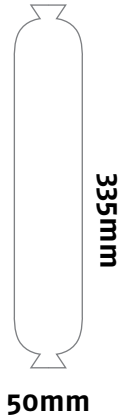

PRODUCT RANGE BY POWER:



PC Cox Ltd., Turnpike Road, Newbury, Berkshire, RG14 2LR
 T Sales +44 (0) 1635 264500 F +44 (0) 1635 264555
 E sales@pccox.co.uk
 www.pccox.co.uk



©PC Cox Ltd. 2015 Cox is a trademark of PC Cox Ltd. Every effort has been made to ensure that the information contained in this leaflet was correct at the time of going to press. However, the company retains the right to change any specification without notice, in line with the company's policy of continual product development.