

LORD TFD[®] Steering Units

FOR STEER-BY-WIRE SYSTEMS



Steer-by-Wire Systems in Industrial and Off-Highway Equipment



Electro-hydraulic and fully-electric Steer-by-Wire (SbW) systems are gaining favor over traditional mechanical and hydraulic steering systems. Vehicles with SbW systems tend to consume less energy, reducing the cost of ownership and improving environmental impact. In SbW systems, there is no mechanical connection between the steering wheel and road wheels, which has challenged OEMs in providing the operator with a high quality steering feel. In response to this challenge, LORD offers a line of Tactile Feedback Device (TFD) steering units.



WHAT IS A TFD STEERING UNIT?

The TFD steering unit is a key component of fully-electric and electro-hydraulic SbW systems. These devices provide an integrated solution that combines bearing support, steering position sensing, communication and continuously variable resistive steering torque, delivering high-fidelity tactile feedback and maximum control to the operator.

LORD Corporation is a pioneer for SbW steering units since 1999, when the first device began production in a forklift truck application. The LORD TFD steering unit is maintenance free and will never require inspection or adjustment during the expected service life. There are very few moving parts in the design which greatly enhances durability. With more than 300,000 devices in service today, LORD Corporation has a long history of providing reliable and safe devices for Industrial and Off-Highway equipment.



HOW DOES A TFD STEERING UNIT WORK?

The TFD steering unit is typically mounted below the vehicle steering wheel. As the operator turns the steering wheel, the hall-effect steering sensor detects and transmits the steering position to the vehicle steering controller. The steering controller uses information from a variety of vehicle inputs to determine the preferred steering response.

The steering response can be programmed for partial or multiple rotations, to be speed sensitive, and to generate end-stop control, position detents and more. Integration with other devices and technologies such as electric motors, GPS and vision systems can provide sophisticated hybrid steering control.



These devices provide an integrated solution for electric and electro-hydraulic Steer by Wire systems.

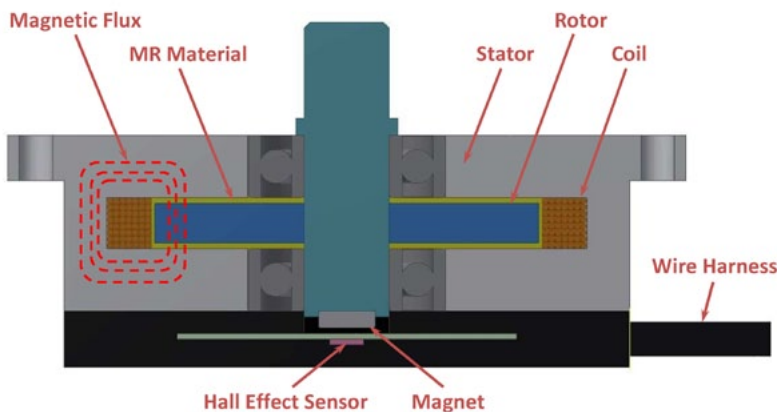

Torque feedback to the operator is generated through our proprietary “Direct Shear Mode” design in which a rotor attached to a shaft shears magnetically responsive (MR) material against a fixed stator. As the current commanded by the vehicle steering controller to the TFD steering unit changes, a low-power (0-1 amp) coil generates a magnetic field that instantaneously changes the properties of the MR material and the subsequent torque feedback.

With torque feedback independent of speed and temperature, a wide variety of applications can benefit from the smooth and quiet steering feel.

BENEFITS OF LORD TFD STEERING UNITS

IMPROVED STEERING FEEDBACK PERFORMANCE

- PROGRAMMABLE RESISTIVE STEERING FEEDBACK BASED ON EQUIPMENT OPERATING CONDITIONS
- SMOOTH STEERING TORQUE INDEPENDENT OF VEHICLE SPEED AND TEMPERATURE
 - NO “STICK SLIP” AT LOW SPEEDS (COMMON WITH FRICTION BRAKES)
 - NO ELECTRIC MOTOR “COGGING” FEEL
- INCREASED EASE OF OFF-ROAD MANEUVERABILITY
- IMPROVED ACCURACY AT ON-ROAD SPEEDS
- LOW POWER CONSUMPTION
- FAST RESPONSE TIME

RELIABLE CONTROL SIGNALS

- MULTIPLE NON-CONTACT SENSOR CONFIGURATIONS (2, 3 OR 4 OUTPUTS)
- ANALOG (V) AND/OR DIGITAL (PWM) OUTPUTS
- PROTECTED FROM EMC
- SIL2/3 SAFETY RATING

INCREASED DESIGN FLEXIBILITY

- EXTENSIVE PORTFOLIO OF STANDARD AND CUSTOMIZED SOLUTIONS
- ROBUST, EASY-TO-INSTALL, COMPACT DESIGN
- IMPROVED STEERING ERGONOMICS FOR THE OPERATOR
- NO MAINTENANCE REQUIRED

Current Applications: Industrial Lift Trucks, Agriculture & Construction Equipment, Electric Vehicles, Marine.

TFD Steering Unit Product Portfolio

LORD Corporation has a diverse portfolio of TFD steering units to satisfy a variety of customer requirements. Our portfolio includes devices capable of producing 5Nm and 12Nm of resistive steering torque.

5NM DEVICES

The adoption of smaller steering wheels has increased as many Industrial and Off-Highway Equipment OEMs consider more innovative and flexible steering interfaces. To meet the various needs of these applications, LORD has developed a standard product line of 5Nm devices which include the following features:

- 2-Channel Dual-Redundant, Non-Contact, Hall Effect Steering Sensor
- Sensor output (three options)
 - Standard digital (PWM) multi-rotational code
 - Analog code suitable for controllers with limited digital I/O
 - Analog multi-rotational code with no discontinuities in the signal
- Shaft connection (two options)
 - Flat
 - Cross-Drilled
- Deutsch DTM04-6P connector
- 20 AWG wire
- 200mm cable length
- 10 Ohm coil

5NM PRODUCT SPECIFICATIONS

Category	Specification
Product Weight	1.3 kg (2.9 lbs)
Rated Torque @ 1A	5 Nm nominal (3.7 lb-ft)
Off-State Torque @ 0A	<0.5 Nm (<0.4 lb-ft)
Operating Speed	180 rpm max
Operating Temperature	-35 C to +80 C (-31 F to +176 F)
Axial Force Limit	1500 N max (337 lbf)
Bending Moment Limit	50 Nm max (36.9 lb-ft)
Current Control	12 VDC
Coil Resistance	10 Ω nominal
Current (max)	1.5 A peak
Current (continuous)	1.0 A
Sensor Resolution	12 bit
Sensor Linearity	+/- 1.2% Full Scale
Environmental Protection	IP66

CROSS DRILLED SHAFT

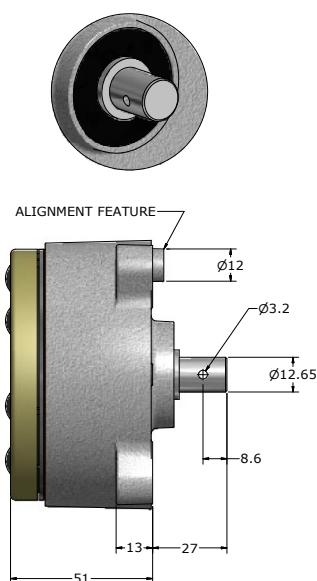
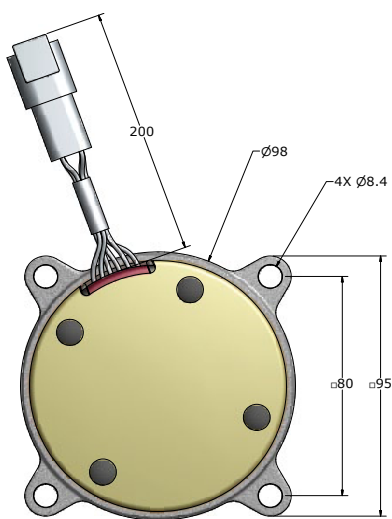

FLAT SHAFT

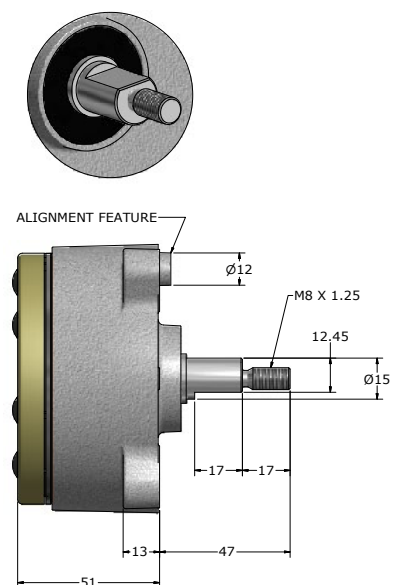

*DIMENSIONS ARE IN MILLIMETERS

12NM DEVICES

For applications with larger steering wheels, LORD has a standard 12Nm TFD steering unit to accommodate the higher steering torque.

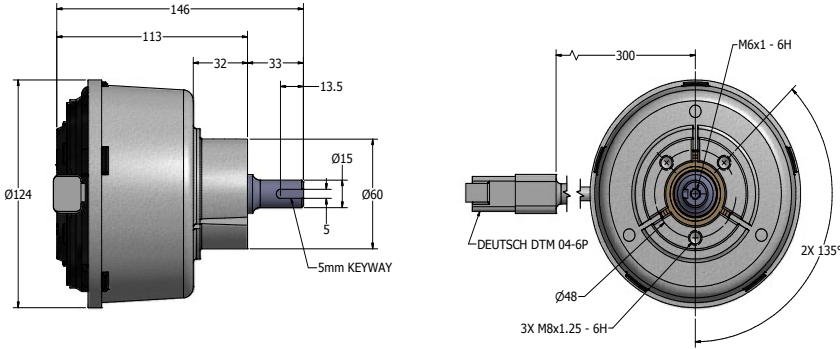

*DIMENSIONS ARE IN MILLIMETERS

CUSTOMIZED SOLUTIONS

LORD also designs and manufactures various customized 5Nm and 12Nm devices, which are tuned to specific customer requirements. These designs may include the following unique features:

- Quad-Redundant steering sensors
- Housings
- Shaft connections
- Cable connections and length
- Coil resistance
- Sensor outputs
- CAN-bus enabled devices

CAN-BUS COMMUNICATION

LORD has integrated CAN capability into our TFD steering unit product line, enabling more sophisticated steering algorithms using various vehicle inputs. Working closely with an OEM, LORD can use CAN-bus communication to enhance the steering feel of a vehicle in ways not possible with previous technology.

12NM PRODUCT SPECIFICATIONS

Category	Specification
Product Weight	2.7 kg (6.0 lbs)
Rated Torque @ 0.8A	10 Nm nominal (7.4 lb-ft)
Off-State Torque @ 0A	<1.0 Nm (<0.75 lb-ft)
Operating Speed	120 rpm max
Operating Temperature	-35 C to +80 C (-31 F to +176 F)
Axial Force Limit	1500 N max (337 lbf)
Bending Moment Limit	50 Nm max (36.9 lb-ft)
Current Control	12 VDC
Coil Resistance	11 Ω nominal
Current (max)	1.5 A peak
Current (continuous)	1.0 A
Sensor Resolution	12 bit
Sensor Linearity	+/- 1.2% Full Scale
Environmental Protection	IP66

CAN-BUS SPECIFICATIONS

Category	Specification
Version	2.0 B
Transceiver Type	High Speed
Speed	250 kbit/sec (programmable)
Message ID Size	11 or 29 bits
Message Output Rate	50 ms (programmable 10 - 100 ms)

LORD Global Presence



UNITED STATES & CANADA

Regional Headquarters:

Cary, NC

Key Products: Adhesives and coatings, industrial parts and assemblies, motion and vibration control technologies, encapsulants, thermal management compounds

EUROPE, MIDDLE EAST & AFRICA

Regional Headquarters:

Geneva, Switzerland

Key Products: Adhesives and coatings, industrial parts and assemblies, motion and vibration control technologies, encapsulants, thermal management compounds

LATIN AMERICA

Regional Headquarters:

Cary, NC

Key Products: Adhesives and coatings, industrial parts, motion and vibration control technologies

ASIA PACIFIC

Regional Headquarters:

Hong Kong

Key Products: Adhesives and coatings, shock, motion and vibration control technologies

KEY MARKETS

AEROSPACE & DEFENSE

- Commercial Aircraft
- Military Aircraft
- Missile Systems
- Military Ground Vehicles
- Aftermarket

AUTOMOTIVE & INDUSTRIAL ASSEMBLY

- Automotive Assembly
- Tier Component Assembly
- Aftermarket Collision Repair
- Electronics
- Industrial Assembly

OIL & GAS & INDUSTRIAL EQUIPMENT

- Oil and Gas
- Off-Highway Vehicles
- Truck & Bus
- Electronics
- Recreational & Marine
- Civil Engineering

LORD provides valuable expertise in adhesives and coatings, vibration and motion control, and magnetically responsive technologies. Our people work in collaboration with our customers to help them increase the value of their products. Innovative and responsive in an ever-changing marketplace, we are focused on providing solutions for our customers worldwide ... Ask Us How.

LORD Corporation World Headquarters

111 Lord Drive
Cary, NC 27511-7923
USA

Customer Support Center (in United States & Canada)

+1 877 ASK LORD (275 5673)

www.lord.com

For a listing of our worldwide locations, visit LORD.com.

LORD Corporation Asia Pacific Regional Headquarters

Central Plaza, Suite 707, 18 Harbour Road,
Wanchai, Hong Kong

LORD Corporation Europe Regional Headquarters

2, Chemin du Pavillon
CH-1218 Le Grand Saconnex
Geneva, Switzerland
+41 22 761 50 74
europesc@lord.com